



Kicker KB600/KB6000 Tower Brackets Installation Instructions and Owners Manual

Monster Tower, LLC
1205 Alpha Drive
Alpharetta, GA 30004

Phone: 877-77-Tower or 770-410-3451
Fax: 877-232-6538 or 770-234-3833
www.MonsterTower.com
Support@MonsterTower.com

THANK YOU FOR YOUR BUSINESS. IF YOU ARE NOT COMPLETELY SATISFIED IN ANY WAY WITH YOUR NEW BRACKETS, PLEASE CONTACT US. Our entire purpose as a company is to offer great products at affordable prices that our customers love.

Please take a few minutes to read the installation instructions and become familiar with the speaker and installation before beginning to ensure a high quality, trouble free installation and use. If you have any questions during your installation give us a call at 877-77-Tower or e-mail Support@MonsterTower.com

NOTES ON INSTALLING AND USING YOUR NEW SPEAKER BRACKETS

- **TOOLS:** A 5 mm and a 6 mm Allen wrench, and an 11/32" bit are required for installation
- Loctite or equivalent thread locker is recommended for all threads
- For best performance, provide 100W-RMS at 4 Ohm to each speaker
- Speakers can be easily removed by removing the two knobs that attach the speaker to the speaker bracket
- Speakers can be pointed to the rider, the cockpit of the boat or the front of the boat by loosening the knobs and rotating the speaker
- Regularly check all hardware to make sure it is tight
- Although the speakers are weather resistant and designed for outdoors use, do not spray directly into the grill with high pressure water
- Speakers can be painted by scuffing the surface with a Scotchbright pad and using catalyzed enamel automotive paint. Remove grill and tape speakers for painting

Waketunes Kicker Speaker Parts List and Assembly Diagrams

Item	Qty	Description
1	2	WakeTunes Tower Collar Bracket
2	4	WakeTunes Plastic Collar Insert
3	2	WakeTunes Speaker Plate
4	2	M8x25 Socket Head Cap Screws
5	4	M6x16 Socket Head Cap Screws
6	2	M8x35 Button Head Cap Screw
7	4	M8x12 Button Head Cap Screws
8	2	Kicker Speaker Bracket (customer supplied)
9	2	Kicker KB600 Speaker (customer supplied)
10	4	Kicker Knob (customer supplied)

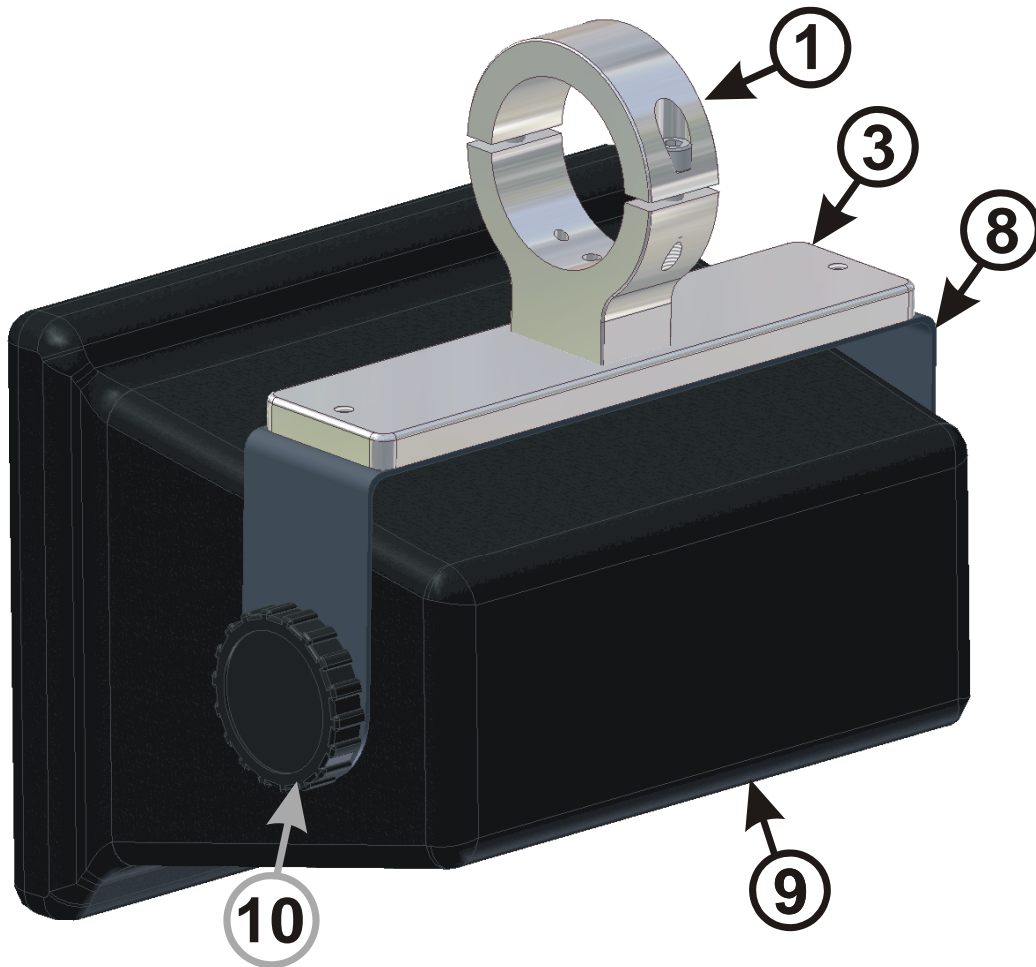

Assembly Instructions

STEP 1: Drill the KB600 Bracket supplied with your speakers to match the below drawing using an 11/32" drill bit. You will need to open the center hole with the bit and remove burrs from each hole.

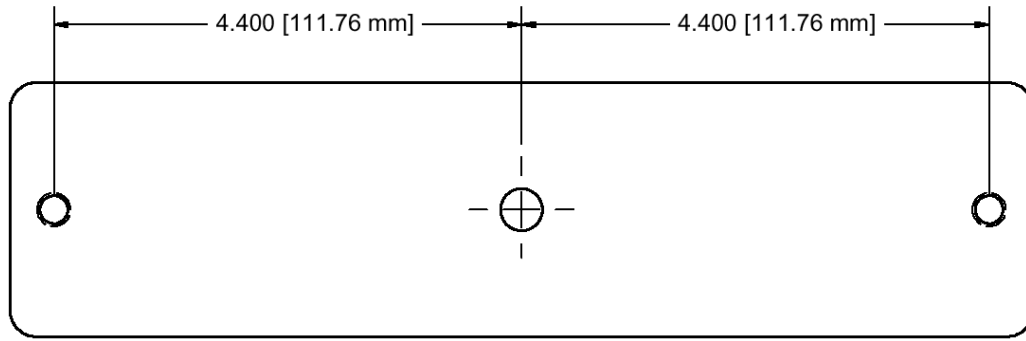

STEP 2: Attach the Collar Bracket (Item 1) to the Speaker Plate (Item 3) using the two M6x16 bolts (Item 5) for each speaker as shown below.

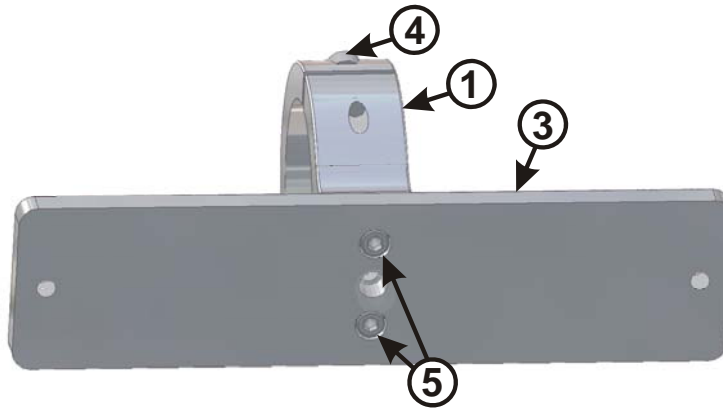

STEP 3: Attach the Kicker Speaker Bracket (Item 8) to the Speaker Plate (Item 3) using One M8x35 bolt (Item 6) in the center and Two M8x12 bolts (Item 7) as shown below.

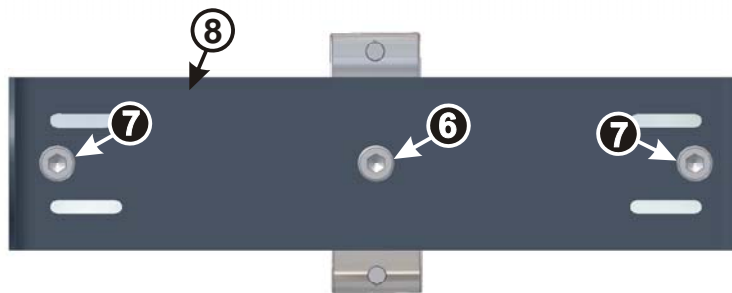

Make sure all bolts are tightened securely (15 ft-lbs) and we recommend using loctite on each thread to ensure they do not loosen from the vibration they will experience on the tower.

STEP 4: Attach the Collar Bracket (Item 1) to the tower using M8x25 bolts (Item 4) and the Collar Inserts (Item 2) that matches your size tower (2-1/2" are provided for Monster Towers and a universal kit with 1-1/2", 1-5/8", 1-3/4", 1-7/8", 2" and 2-1/4" are provided for other towers).



STEP 5: Attach the KB600 Speaker (Item 9) to the Speaker Bracket (Item 8) using the two quick release knobs (Item 10). Connect your speaker wire to the back of the speaker and enjoy!

Wiring Instructions and Amplifier Considerations

We recommend you use 16 to 18 gage wiring between the speakers and amplifier. Consult your tower installation manual or provider for instructions on running wire inside your tower. We recommend covering the wiring with 3/8" or 1/2" wiring loom and electrical tape as shown for a professional, watertight appearance.

The most common way to wire a boat with tower speakers is with the front speaker or front pre-amp outputs of the stereo driving all speakers in the boat. The rear speaker or rear pre-amp outputs are then used for the tower speakers. This allows the fader to control the volume from inside to behind the boat.

A four-channel amplifier in the boat is typical with two channels driving the boat speakers and two channels driving the tower speakers. The next level is to have separate amplifiers for the boat and for the tower speakers.

The Kicker KB600 speakers are rated to handle 75W RMS at 4 Ohms. The peak power of an amplifier is what is advertised but also often misleading. The RMS at a specific Ohm Load is the real working power of the amplifier. It is generally agreed by audiophiles that supplying too much power to speakers is far better than under powering the speakers. If there is too much power the signal "clips off" and the speakers let you know with no damage. With too little power you send lots of distortion to the speaker which causes speaker damage. It's far better to "over amp" the speakers and not turn it up all the way than "under amp" them and send up damaging distortion.

Most amps have a Bass boost or filter that you can use to remove or add Bass. Turn this off or put on the lowest setting to remove as much Bass as possible to the tower speakers. If your amp has a High Pass Filter turn it to the highest frequency to filter out as much Bass as possible. The Bass uses the majority of the amplifier power with sound that will not reach the rider. Mostly high frequency and some mid-Bass will be audible at 65'-80' behind the boat over engine, water and wind noise.

For learning more about tower audio, we highly encourage you to visit the "Boats and Accessories" discussion boards at www.Wakeboarder.com and www.WakeWorld.com and www.diyTower.com.



Monster Tower, LLC Warranty for WakeTunes Products

Monster Tower warrants this product against manufacturers defects for a period of five (5) years. Anodized surfaces are specifically excluded, as their care and use cannot be controlled by the manufacturer. Any modifications or improper use, not approved in writing by Monster Tower, shall void this warranty. Monster Tower is not responsible for personal injury or damage to the boat caused by the use of this product. Monster Tower's obligation under this warranty shall not include any transportation charges or costs of installation or any liability for direct, indirect or consequential damages resulting from delay or improper installation. If you need to make a warranty claim contact Monster Tower at 877-77-Tower to receive a return authorization, number which is required for all claims. Defects must be reported within 30 days of discovery.